

FLOWPLATE

Manufacture of traffic flowplates

Flow Plates Ltd

Unit 28D, Nuralite Industrial Estate, Canal Road, Higham, ME3 7HT

T: 0333 433 0468

E: sales@flowplates.co.uk

W: www.flowplates.co.uk

O&M MANUAL



STANDARD FLOWPLATE

PART NO NMFP - 03

FLOWPLATE

Manufacture of traffic flowplates

Flow Plates Ltd

Unit 28D, Nuralite Industrial Estate, Canal Road, Higham, ME3 7HXT

T: 0333 433 0468

E: sales@flowplates.co.uk

W: www.flowplates.co.uk

Product Overview

Standard Flow Plate

The standard flow plate is an ideal solution for smaller car parks with a low to medium yield of traffic flow. Manufactured in the UK, this is a tough and durable product designed to encourage the flow of traffic in one direction. The standard flow plate is manufactured in chequer plate and finished in a bright yellow for added visibility. Speed ramps should be used in conjunction with this product to ensure that traffic drives over at the correct speed (5mph).

This product is only suitable for cars and light commercial vehicles up to a maximum of 1 ton per axel. Standard flow plates are bolted to the surface using 6 fixing bolts which makes this a good solution for multi-story car parks and areas where excavation is not possible.

**** Not suitable for use by HGV's ****

Specification

Material: Chequer plate steel
Dimensions: 250mm (depth) x 366mm (width) x 100mm (flap upright)
Height of plate with flap depressed is 34mm
Weight: 12 kg
Installation: Surface mounted

We strongly recommend the use of warning signage and speed ramps in conjunction with HGV Flow Plates.

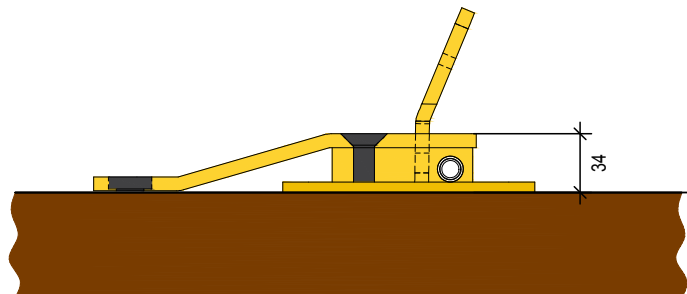
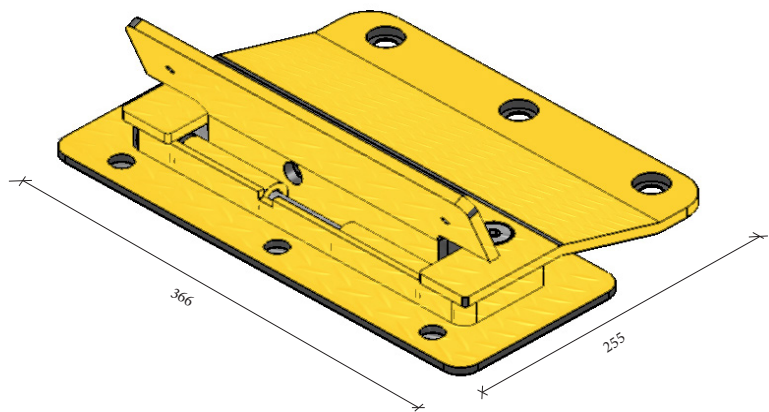

Section AA

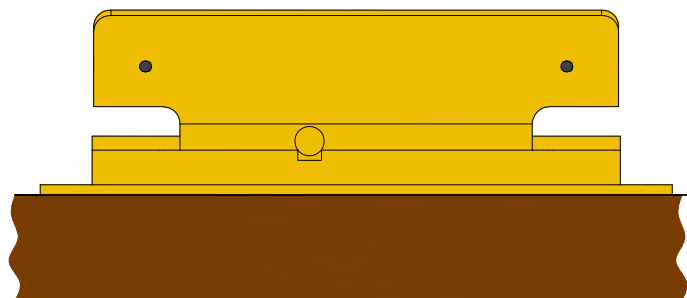

Elevation

This manual is a guide ONLY and above all common sense should prevail we cannot as an individual or a company be held responsible for any accident damage or indeed any event that happens with the afore mentioned equipment or any variant of this. This article is intended as a basic user guide and is NOT a comprehensive "how to" when using the Flow Plates system. You must only use the equipment if you feel you have an understanding of the operation and confidence in yourself to adhere to the signage and warnings that have been outlined to you in this manual and displayed next to the equipment. Also this guide should be given to you complete with warnings and all pages from its original not a cut down or modified version.

NB: Only competent skilled persons should carry out procedures or a variant of procedures detailed in this manual



IMPORTANT SAFETY NOTICE

Flow Plates and ramps are designed to Control the flow of vehicular traffic primarily. It can be dangerous to allow the passage of pedestrians and any other self-powered animal or device to utilize this method of access without appropriate warnings and or signage.

It may be necessary for the end user of this product to provide an alternative, safe method of access to cater for the previously mentioned categories.

The end user should fit all necessary signage and warning notices to either side of the flow plates installed, which should be visible and clear from all directions of approach.

The product that was shipped to you was designed with the best intentions to protect all categories from harm or affect this however is not a fail safe. They should not be modified or tampered with by any unauthorised person not sanctioned by the manufacturer.

Sign and date below to say that you have read and understood this notice before ANY installation work:

_____ / / 20

FLOWPLATE

Manufacture of traffic flowplates

Flow Plates Ltd

Unit 28D, Nuralite Industrial Estate, Canal Road, Higham, ME3 7HXT

T: 0333 433 0468

E: sales@flowplates.co.uk

W: www.flowplates.co.uk

Instructions for use and maintenance

Flow plates have been designed to encourage vehicles to travel in one direction only. The use of flow plates by pedestrians is not recommended, as it is important to use common sense to avoid trapping any bodily parts and ensure that the product is used safely over its' life span. As much as is possible, any part or component that could cause harm has been manufactured to offer the greatest protection to the user. Used sensibly and with the appropriate understanding of this product, these products will continue to operate in a safe manner.

Positioning:

- To maximise the life of your Flow Plates, vehicles should drive over the product in a straight line as demonstrated in diagram below. Vehicles turning on the Flow Plates can cause excessive discomfort to the passengers and will also damage the Flow Plates, springs, fixings and can affect the position on the surface.
- Flow Plates should be set back from junctions, to reduce vehicles stalling when pulling away
- It is best practice to fit Flow Plates on a level surface and not on an incline or slope as in certain circumstances dependant on the traffic type, damage may be caused to the Flow Plates and could reduce the life span of the product
- Flow Plates are not to be fitted on a gravel road as this can cause damage to the Flow Plate, it's mechanism and reduce the life span of the product.

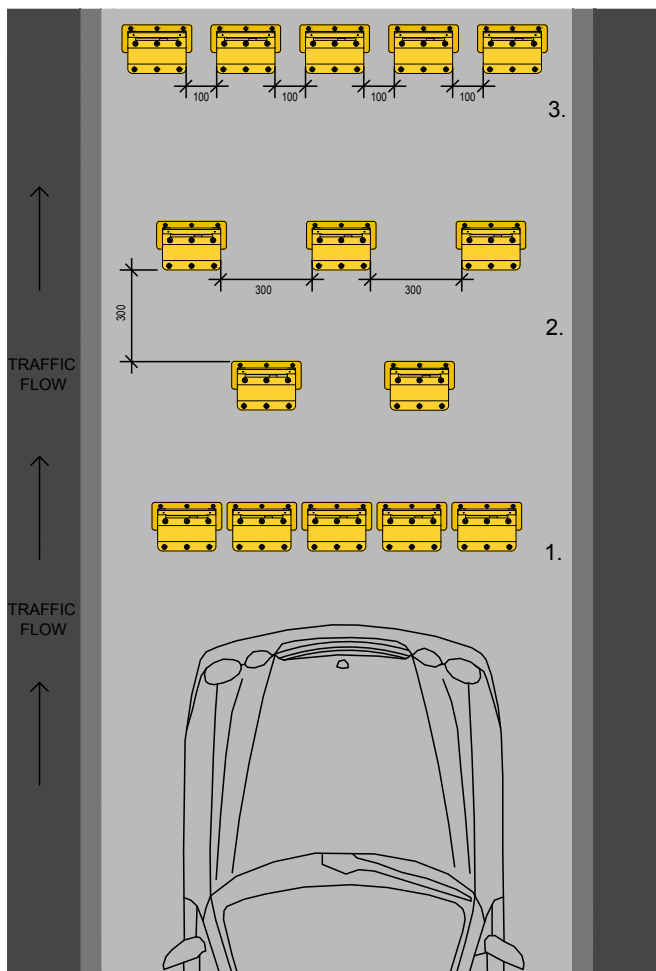

Note: All Flow Plates should be set out as shown in the diagram away from an area of turning

FLOWPLATE

Manufacture of traffic flowplates

Flow Plates Ltd

Unit 28D, Nuralite Industrial Estate, Canal Road, Higham, ME3 7HXT

T: 0333 433 0468

E: sales@flowplates.co.uk

W: www.flowplates.co.uk

Installation Methods:

The Flow Plates can be installed on to either a tarmac or concrete surface.

Tarmac surface fitting instructions:

This method should only be used if the asphalt surface is older than 6 months and has a crust of asphalt depth of 50mm or greater (for newly laid tarmac a concrete raft should be laid and concrete fixings used). The Flow Plate or Ramp should be fitted to tarmac surfaces using Rubber Expanding Bolts, these are a high density rubber product with a nut moulded into the base. Rubber fixing plugs have an outside diameter of 24mm and are 75mm in depth; the actual steel bolt size is an M12 x 100mm.

- STEP 1. Set out all of the flow plates on the tarmac in the desired position
- STEP 2. Drill holes for all plates should be marked out on the tarmac
- STEP 3. Remove all of the plates and drill all the holes to the full depth (100mm)
** Do NOT fit any plates until all of the surface holes have been drilled out
- STEP 4. Fit the rubber fixing to the underside of each plate using the steel bolt, tighten by hand
- STEP 5. Lay all the plates over the holes and gently tap the plates to slot the rubber fixings into the holes with a mallet or similar
- STEP 6. Once all the plates are in position, tighten with an impact driver or socket

DO NOT OVER TIGHTEN THE FIXINGS !

Important note: The rubber plugs and fixing bolt should be fitted to the product prior being dropped into location. Once the bolts have been loosely fitted drop the entire unit into the pre-drilled holes, you will save hours of time!

Tools and Equipment you will need:

- 1. A robust drill that can take a 24mm masonry drill bit
- 2. 24mm masonry drill bit
- 3. 19mm spanner or impact driver with a 19mm socket
- 4. A string line to ensure plates are aligned correctly

Concrete surface fitting instruction:

Where a tarmac surface is in poor condition, has a surface depth less than 50mm or is newer than 6 months old, it is recommended that a concrete raft is laid for the flow plates to be installed on to.

FLOWPLATE

Manufacture of traffic flowplates

Flow Plates Ltd

Unit 28D, Nuralite Industrial Estate, Canal Road, Higham, ME3 7HXT

T: 0333 433 0468

E: sales@flowplates.co.uk

W: www.flowplates.co.uk

Road width metric (mm)	No. of plates
2500	6
3000	8
3500	9
4000	10
4500	12
5000	13
5500	15
6000	16
6500	17
7000	19

Table 1. Widths to plate number

Quantity of flowplates is dependent on the width of the roadway. Refer to table. When in doubt please contact a member of the sales team for further clarification.

Maintenance

Depending on site usage in order for these units to operate to their optimum they should be serviced once a year. Refer to the bullet points below for general product maintenance.

- Sweep the area surrounding the flow plates to avoid excess dust and debris build up in the moving mechanism part
- Undo the plate fixings and remove the cover to clean out all debris. This will inhibit the smooth movement of the teeth and/or flap
- Check all ground fixings are tight as lateral movement in the plates will cause excess wear
- Paint finish should be re-coated whenever the zinc coated finish has worn through. It is normal for the finish to deteriorate over time as the plates are bearing heavy traffic.
- Springs can wear over time and should be replaced once they become worn, or are not working effectively.



PLEASE PAY ATTENTION AND CONE AND SECURE
YOUR AREA OF WORK BEFORE! ANY WORK IS
CARRIED OUT

YOU MUST USE COMMON SENSE TO AVOID ANY
INJURY

